

Solar cells

March 10th 2009
Turid Worren Reenaas
Turid.Reenaas@ntnu.no

TEP4150

1

Overview

- Part 1: Basic solar cell theory
 - What is a solar cell? How does it work?
 - Energy band diagrams, bandgap
 - pn-junctions
 - Loss mechanisms
- Part 2: Second and third generation solar cells
 - What is the maximum efficiency for a solar cell?
 - Solar cell generations
 - Third generation “the 2020 vision”
 - Commercial solar cells

2

What is a solar cell?

- A solar cell is a device that converts sunlight (electromagnetic radiation) directly to electric energy.
- The energy of the electromagnetic radiation is quantized, into “packets” called photons.
- The energy of a photon equals

$$E_{\text{ph}} = hf = hc/\lambda,$$
 where f is the frequency and λ is the wavelength of the radiation, h is Planck's constant and c the speed of light.)

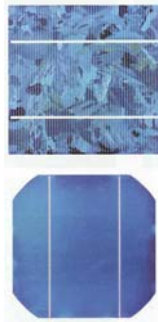

3

- A solar cell can only utilize photons with energy larger than a certain threshold (equal to the “band gap” of the solar cell material).
- Inside the solar cells the energy of the absorbed photons is given to the electrons in the solar cell, so that they become more mobile and can set up an electronic current.

4

The solar spectrum

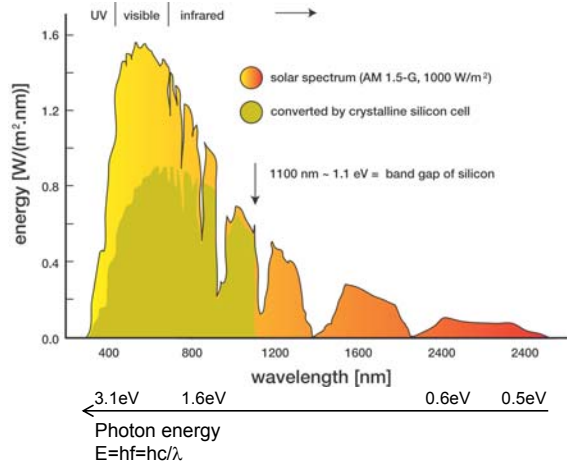

5

How does a solar cell work?

- A solar cell delivers current to a load as long as the sun is shining

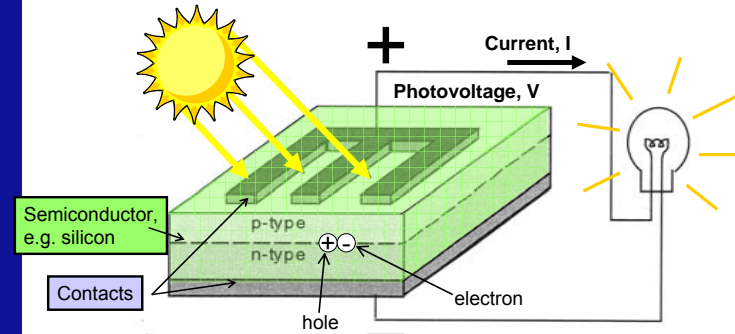

6

Photovoltaic effect (≠ photoelectric effect)

- In the semiconductor in the solar cell, a current is created by the generation of free charge carriers (electron and hole pairs) due to absorption of solar radiation. The electrons (and holes) flow towards the electrodes (by drift in the built-in electric field and diffusion) on the outside of the solar cell.
- The (steady-state) charge that builds up on each side of the solar cell sets up a (photo-)voltage over the external electrodes. It is this voltage that drives the electrons out of the solar cell and through the load (e.g. a lamp).
- This is called the *photovoltaic effect*, **PV**.

7

Basic solar cell operation:

To create an electric current that

does something useful on the

outside of the solar cell.

8

Where does the electron-hole pair come from?

How can we make them leave the solar cell?

Analogy

- People attending a U2 concert are the electrons inside a semiconductor
- The music will “excite” the people and solar irradiation will excite the electrons in a semiconductor
- People are electrons
- Music is light

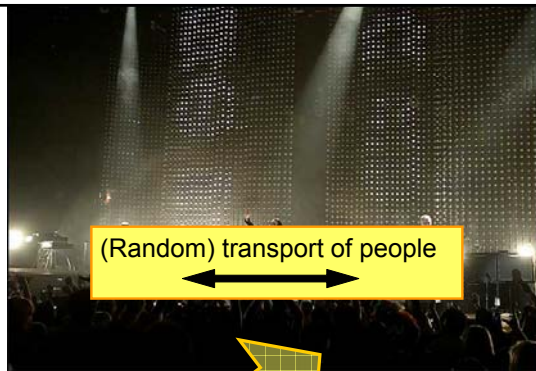

U2 in concert



U2 fans that can be excited by the music

A hole

- In the semiconductor electrons are excited to a higher energy level by absorption of the solar radiation.
- Before excitation the electrons are taking part in binding the semiconductor atoms together (they are binding electrons with energy in the so-called *valence band*),
- and after excitation they are free to move around and conduct an electric current (they are conduction electrons in the *conduction band*).
- An empty state (a hole) is left in the lower level; the valence band.

Simplified energy diagram for a conventional solar cell*

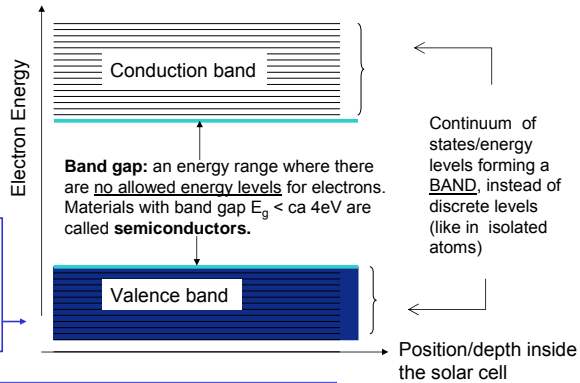

At $T=0$ (and in the dark) all states in the conduction band are empty and all states in the valence band are filled.

*Omitting the pn-junction and contacts

Simplified energy diagram of a conventional solar cell*

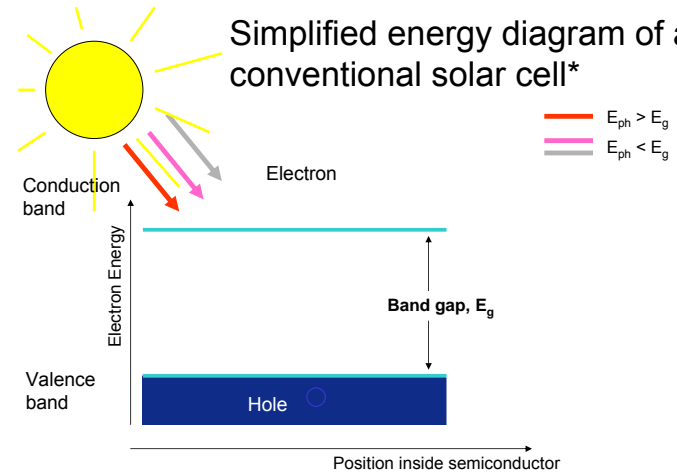

In the absorption of a photon (with $E_{ph} > E_g$) an electron-hole pair is created.

The electron gives up the excess energy from the photon, when passing through the load.

*Omitting the pn-junction and contacts

We want to avoid that people fall down again, to make sure that they can do something useful on the outside of the concert arena:

We introduce a force that separates the person from the empty state:

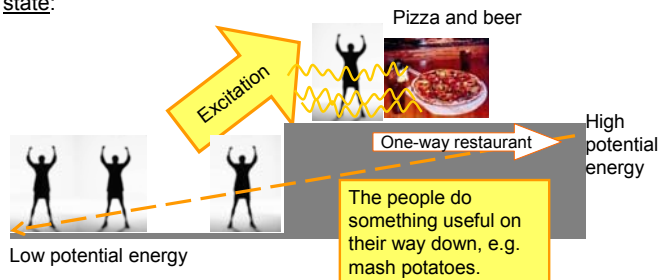

How can we make the "one-way" restaurant inside the semiconductor of the solar cell?

"One-way" restaurant in the solar cell

- To separate the electron from the hole in the solar cell a built-in electric field is utilized.
- The hole is a missing electron and moves in the opposite direction of the electron, and has a positive charge.
- In an electric field, the electron and hole will be separated, since they have opposite charge.
- The built-in field is normally created by making a pn-junction in the semiconductor.
- The pn-junction is made by adding small amounts of atoms (dopants) that can increase (to create a n-type semiconductor) or lower (for p-type) the number of free electrons in the semiconductor.

Silicon atoms, Z=14 (silicon is the semiconductor that is used in >90% of commercial solar cells)

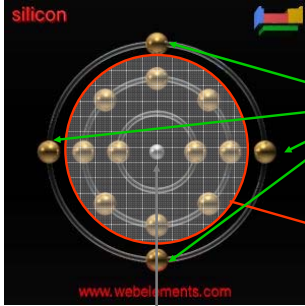

Valence electrons, taking part in the bonding of the silicon. (Covalent bonds)

"Silicon core" = atom nucleus plus electrons in filled electron shells

Nucleus with 14 neutrons and 14 protons.

Doping

Each Si atom has 4 valence electrons (electrons in the outermost shell). Each Si atom is sharing 4 valence electrons with its nearest neighbours, so that it has 8 in total (and has filled the outer shell).

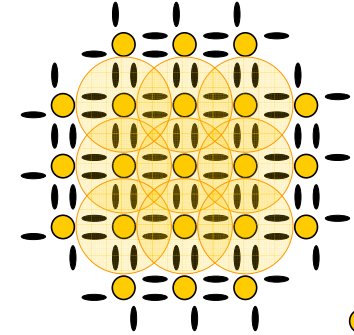

● Valence electrons, taking part in bonding
● Si nucleus + electrons in filled shells (that do not take part in the bonding)

P-doping

Replace one silicon atom with an atom that has only three valence electrons (i.e. boron, Z=5).



Nucleus with 5 neutrons and 5 protons.

5 electrons in total, 3 in outermost shell (valence electrons)

When the boron atom accepts one electron from the surrounding silicon, to fill its outermost shell, locally there will be a net negative charge where the boron atom is located.

P-doping

The p-dopant can accept electrons from the silicon atoms, and are called acceptors.

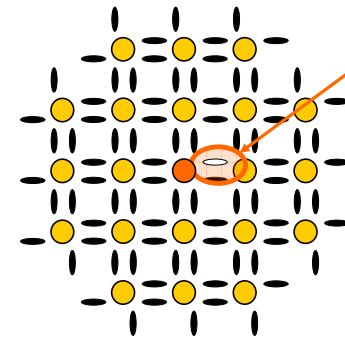

A hole, that can be filled by near by electrons, and then the dopant is ionized, and negatively charged.

● Binding electrons, keeping the material together
● Si nucleus + electrons in filled shells (that do not take part in the bonding)

N-doping

Replace one silicon atom with an atom that has five valence electrons (i.e. phosphorus, Z=15).



Nucleus with 15 neutrons and protons.

15 electrons in total, 5 in outermost shell (valence electrons).

When the phosphorus atom donates one electron to the surrounding silicon, one electron will be missing to maintain charge neutrality, so locally there will be excess positive charge where the phosphorus atom is located.

N-doping

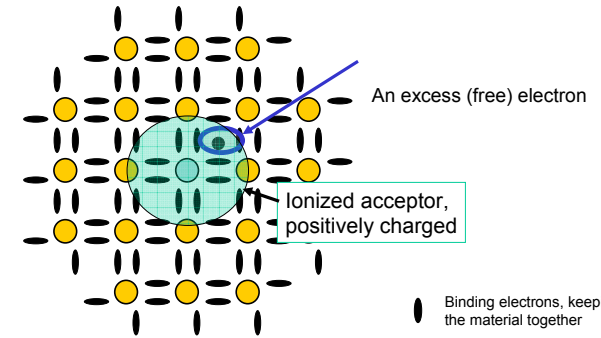

- Binding electrons, keeping the material together
- Si nucleus + electrons in filled shells (that do not take part in the bonding)
- Conduction electrons

pn-junction

To create an built-in electric field : join a p-type and an n-type semiconductor, to create a pn-junction.

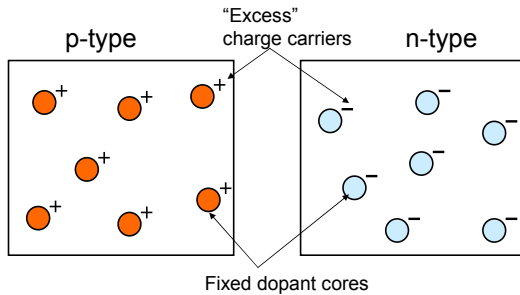

Here shown before ionization of the dopants; In the ionization process the free carriers will be (thermally) released to the surrounding semiconductor.

What happens when the p- and n-type materials are brought together?

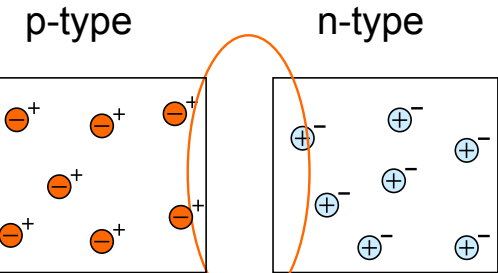

At the junction electrons diffuse from the n-type to the p-type semiconductor, where they recombine with available holes.

An opposing electric field builds up due to the charge associated with the ionized donor and acceptor atoms.

Electrons generated on the p-side will drift to the n-side

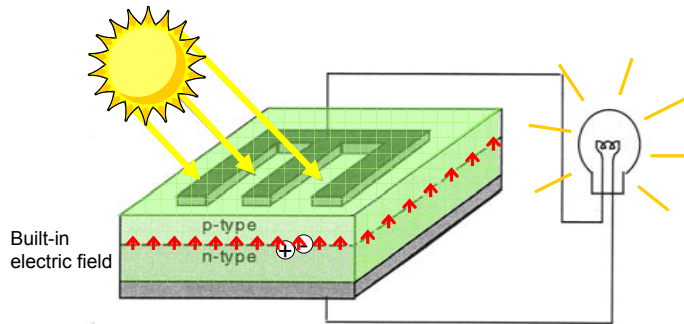

The electrons and holes drift across the pn-junction due to the electric field, and then diffuse to the external contacts.

Current-voltage characteristics of the solar cell

- A solar cell in the dark behaves like a diode (a pn-junction):
 - if there is a positive voltage over the diode/pn-junction (+ connected to the p-side of the junction), the current will increase exponentially as the voltage increases
 - if there is a negative voltage over the diode/pn-junction (- connected to the p-side of the junction), almost no current will flow, even when the voltage increases

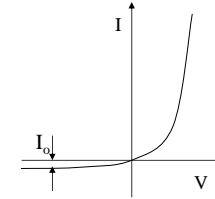

$$I_D(V) = I_0 [\exp(qV/kT) - 1]$$

where q is the electron charge, k is the Boltzman constant, and T is the temperature.

Solar cell under illumination

- The solar cell under illumination, can be regarded as a current source (where the amount of current is proportional to the intensity of the illumination, G), connected in parallel with a diode:

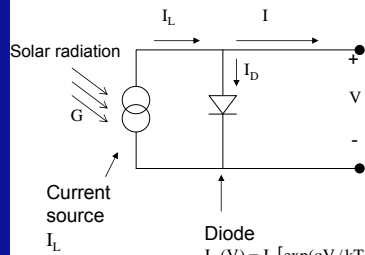

The current generated by the illumination equals I_L and flows in the opposite direction of the diode (dark) current I_D .

The total current delivered by the solar cell equals $I = I_L - I_D$ (or $-I = I_D - I_L$).

IV-characteristics under illumination

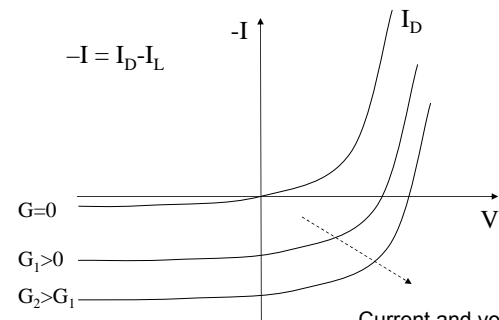

Current and voltage increases with increasing illumination (irradiance G)

IV-characteristics under illumination

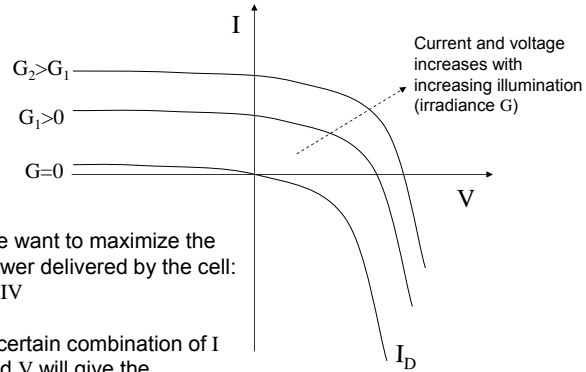

We want to maximize the power delivered by the cell:
 $P=IV$

A certain combination of I and V will give the maximum power.

Loss mechanisms and conversion efficiency limits

Solar cell conversion efficiency η :

$$\eta = \frac{\text{delivered electric power}}{\text{incoming solar power}}$$

$$= \frac{U \cdot I}{P_{\text{sun}}}$$

- We want to maximize the product of the voltage and the current delivered by the cell
- What mechanisms limit the amount of current and voltage delivered by the cell?

The two major loss mechanisms

Too high excitement is a waste of energy

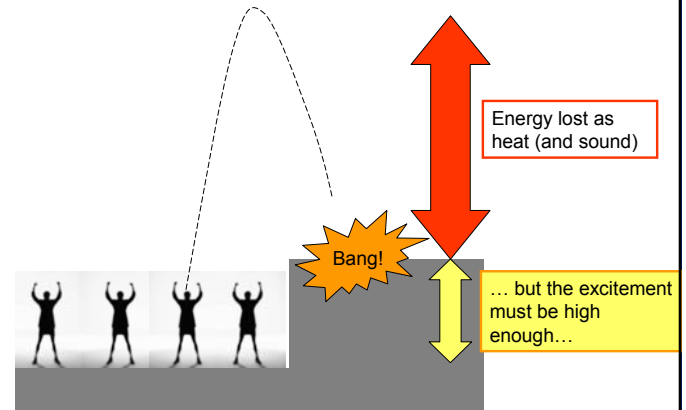

The size of the photo-voltage

- The energy difference between the lower and higher level sets an upper limit of the photo-voltage.
- The larger the energy difference, the larger the photo-voltage.
- In the analogy: the higher the height difference between the upper and lower level, the more potential energy available for making mashed potatoes, but ...

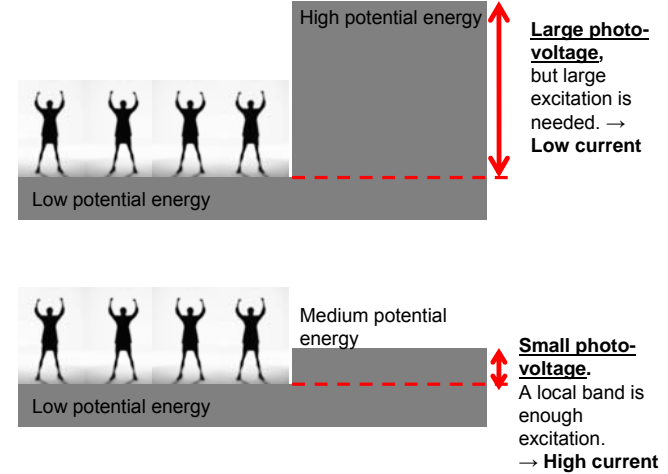

Remember: electric power is current times voltage $P = I \times U$

Solar cells and the solar spectrum

- The maximum photo-voltage for the solar cell is (in part) determined by the semiconductor that is used. The larger bandgap (the energy separation between the lower and upper level) the semiconductor has, the larger the photo-voltage can be.
- The amount of current generated is determined by the intensity of the solar radiation (with photon energy larger than the bandgap).
- The solar spectrum (at the surface of the earth) covers the wavelength range from ca 300 to 2500nm.
- In the analogy: Each wavelength in the solar radiation would correspond to a separate rock band. Some of the bands can excite to very high levels, others can not even excite to a medium level.

Silicon and the solar spectrum

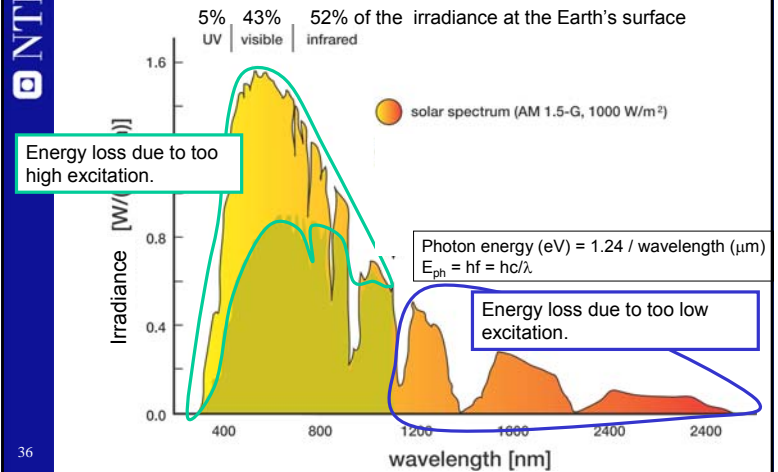

Losses in solar cells

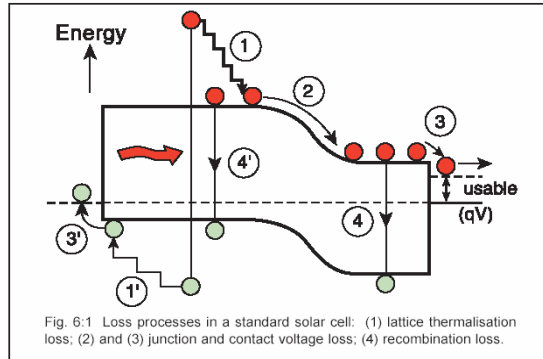
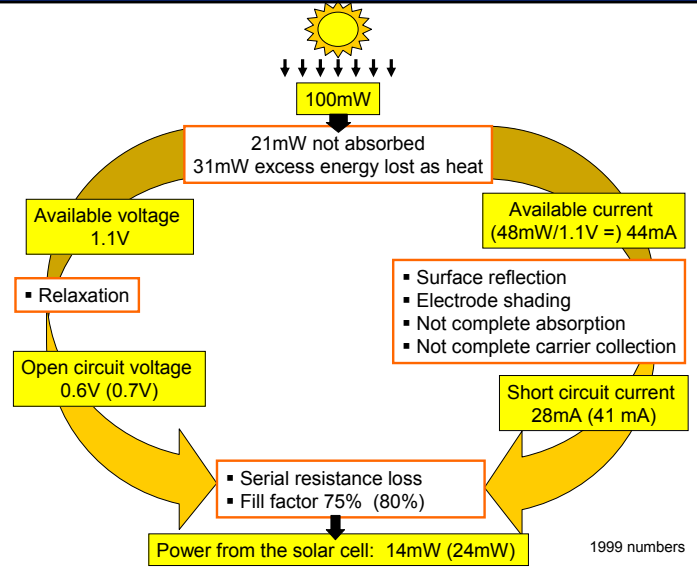

Fig. 6-1 Loss processes in a standard solar cell: (1) lattice thermalisation loss; (2) and (3) junction and contact voltage loss; (4) recombination loss.



Theoretical limit single junction cell

The theoretical limit for a single pn-junction solar cell, E_g (dir) = 1.11eV:
 $\eta = 40.5\%$ (direct illumination)

Commercial silicon solar cells have an efficiency of 12-17%.
 (Lab record 25%)

High-performance (PERL) cell

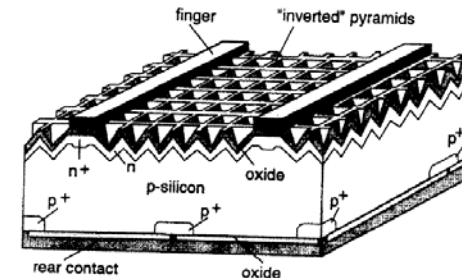

Fig. 8 High-performance PERL cell.

Summary solar cell operation

- A solar cell converts solar radiation to electric energy, by absorption in a semiconductor.
- Under illumination the solar cell generates current that is driven out of the cell by a (photo-)voltage, e.g. it works like a regular battery.
- The amount of current generated depends on the intensity of the solar radiation
- The maximum size of the (photo-)voltage depends of the material the solar cell is made of.

- The smaller the bandgap the more of the solar spectrum will be absorbed, and more current will be generated, BUT the voltage on the terminals of your solar cell will be small.
- You have to make a choice between large current or large voltage, and for a given incident spectrum there is an optimum band gap that maximizes this product.

Solar cells – part 2

- Part 1: Basic solar cell theory
 - What is a solar cell? How does it work?
 - Energy band diagrams, bandgap
 - pn-junctions
 - Loss mechanisms
- Part 2: Second and third generation solar cells
 - What is the maximum efficiency for a solar cell?
 - Solar cell generations
 - Third generation “the 2020 vision”
 - Commercial solar cells

Part 2: Second and third generation solar cells

How much of the energy from the sun can be utilized in a solar cell?

Look at sun+earth as a Heat Engine

The sun, temperature 6000K

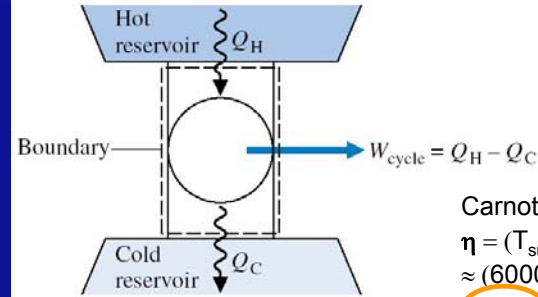

Carnot-limit of efficiency
 $\eta = (T_{\text{sun}} - T_{\text{earth}})/T_{\text{sun}}$
 $\approx (6000\text{K} - 300\text{K})/6000\text{K}$
 $= 94\%$

The earth, temperature 300K

Cost

- Solar cells can not be too expensive.
- 70% of the production cost is materials cost
- This started the "quest" for cheaper solar energy: thin film based solar cells and organic solar cells.
- It is anticipated that for these also the materials cost will dominate the cost eventually.
- A new goal emerged: develop solar cells with 2-3 times higher efficiencies.

Efficiency vs. price

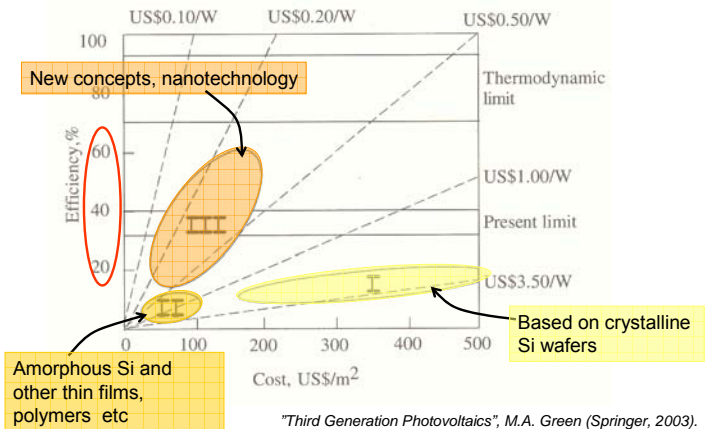

1st and 2nd generation

- 1st generation ($\eta = 15\text{-}20\%$, **3,5\$/W**)
 - Silicon: single crystals and multicrystalline

Medium efficiency, but expensive.

- 2nd generation ($\eta = 1\text{-}15\%$, **1,0\$/W**)
 - Thin films: Si, CdTe, CuInGaSe_2 (CIGS), polymers etc.
 - Grätzel-cells (dyes in a porous nanocrystalline TiO_2)

Cheap, but low efficiencies.

How can we work around the two major loss mechanisms?

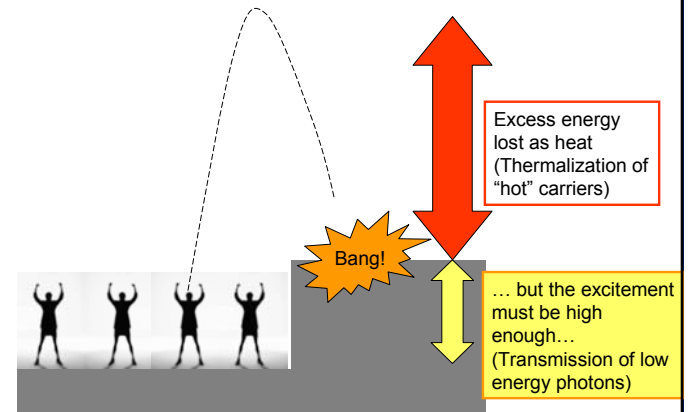

3rd generation ("2020 vision")

- New concepts
 - Hot-carrier cells (capture un-thermalised charge carriers)
 - $\eta = 85.4\%$
 - Multiple charge carriers per absorbed photon by impact ionization (Quantum efficiency $QE > 1$)
 - $\eta = 85.9\%$
 - Multiple band gaps (i.e. tandem cells, intermediate band cells) (Split the solar spectrum and convert it in several solar cells with different bandgaps.)
 - $\eta = 86.8\%$

- **Hot carrier solar cells: capture the excited electron hole pair before they thermalize**

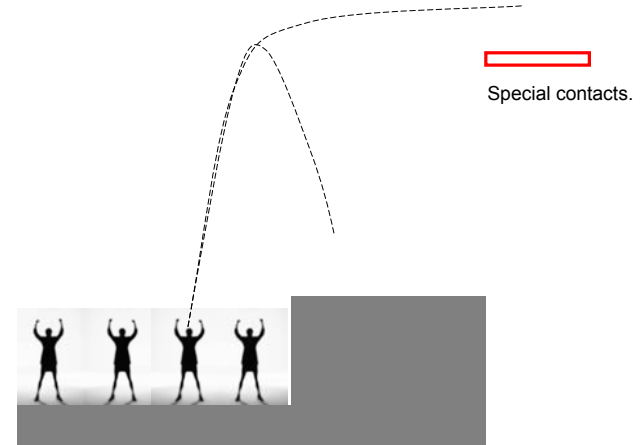

"Hot carrier" cells ($\eta = 85,4\%$)

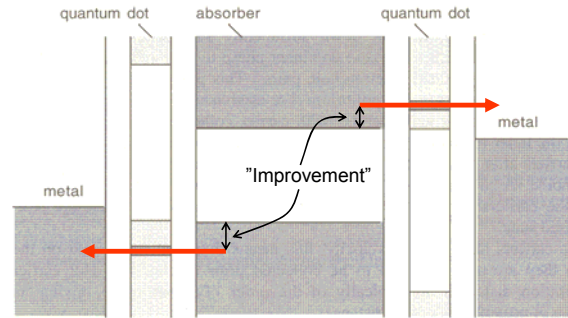

53

"Third Generation Photovoltaics", M.A. Green (Springer, 2003).

- **Impact ionization:** use the excess energy to excite another one

Quantum efficiency larger than 100%:
one photon gives several electron hole pairs

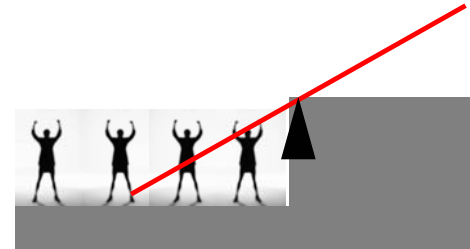

54

Multiple electron-hole pairs per photon ($\eta = 85,9\%$)

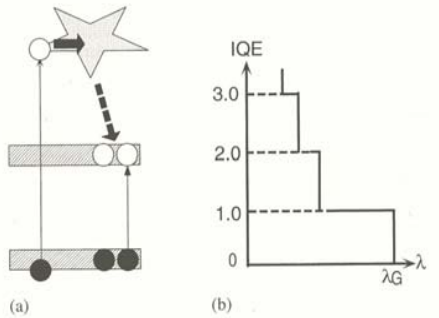

55

"Third Generation Photovoltaics", M.A. Green (Springer, 2003).

- **Tandem cells (also called multi-junction)**

Several solar cells placed after each other.

Each solar cell is supposed to utilize a part of the solar spectrum, and the rest is transmitted to the cell below.

The more cells/bandgaps the better the total efficiency will be.

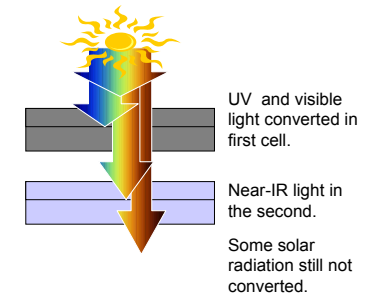

56

- **Intermediate band solar cells:** increase absorption of low energy photons via intermediate bands

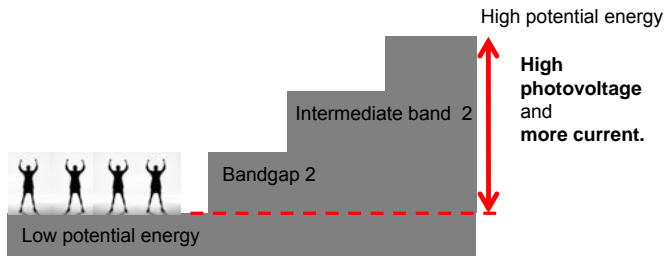

This is a subgroup of third generation cells, where the solar cells have multiple bandgaps. Another example in this subgroup is the *tandem cell*, where (two or more) cells with increasing bandgap are placed on top of each other.

Intermediate band solar cell

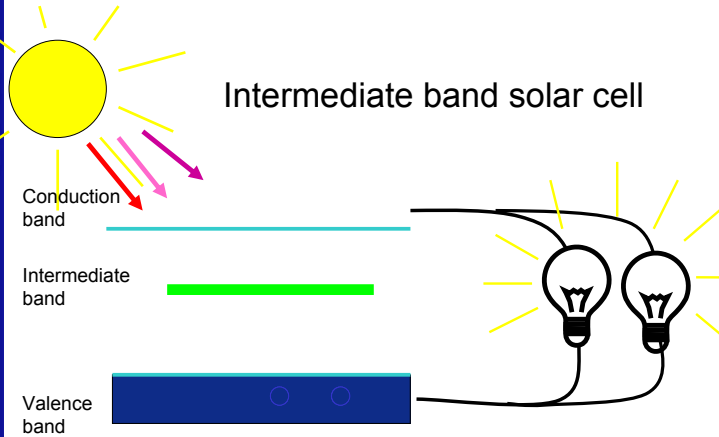

Increase the photo-generated current without reducing the bandgap and thus the voltage.

NREL tandem cell

“2 solar cells in one device”

Max efficiency 56% (two cells)

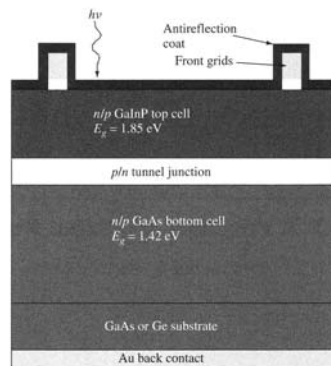

$$\text{Solar cell efficiencies} = \frac{\text{Electricity output}}{\text{Solar energy input}}$$

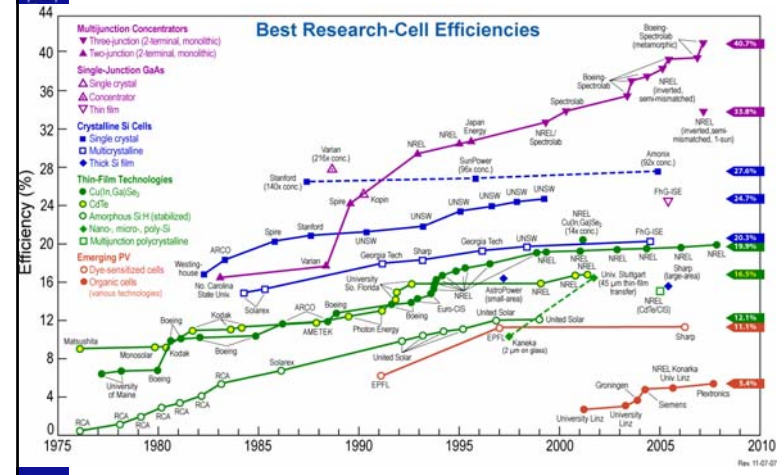

http://www.ise.fraunhofer.de

Fraunhofer
 Institut
 Solare Energiesysteme

Press Release

Freiburg
 January 14, 2009
 No. 01/09
 Page 1

World Record: 41.1% efficiency reached
 for multi-junction solar cells at
 Fraunhofer ISE

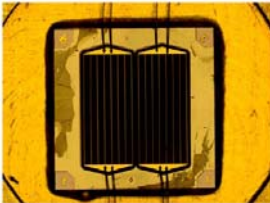

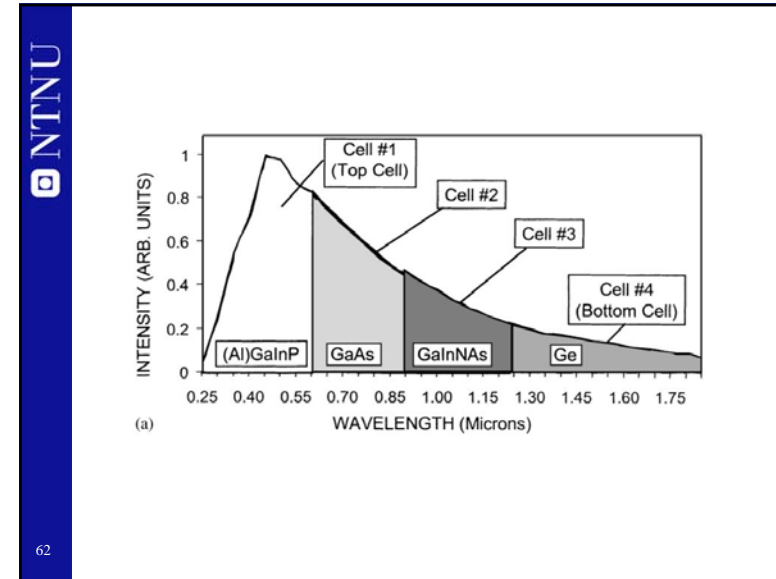



Figure 1: Photo of the new world record solar cell made of $\text{Ga}_{0.52}\text{In}_{0.48}\text{P}/\text{Ga}_{0.47}\text{In}_{0.53}\text{As}/\text{Ge}$ with a cell area of 5.09 cm^2

61



62

Conversion layers

- Instead of altering the solar cell design, an alternative is to alter the solar spectrum before it enters the solar cell. This can be done in two ways:
 1. Down-conversion
 - Split a high energy UV-photon into two (or more) lower energy photons that can be absorbed in the solar cell.
 2. Up-conversion
 - Use two (or more) low-energy photons to generate one of higher energy that can be absorbed.

63

Commercial solar cells

- Silicon
 - (single crystal, sc-Si or c-Si), (multi-crystalline mc-Si), amorphous (a-Si)
- III-V based
 - compounds made up of elements from group III and V in the periodic system (e.g. GaAs, InAs, InP, $\text{In}_x\text{Ga}_{1-x}\text{As}_{1-y}$)
- Cadmium-telluride CdTe
- Chalcopyrites
 - Copper-Indium-Gallium-di-Selenide $\text{Cu}(\text{Ga},\text{In})\text{Se}_2$ CIGS and similar
- Dye sensitized solar cells
 - organic molecules on an inorganic carrier, liquid electrolyte
- Organic (polymer) solar cells
 - semiconducting polymers

64

Snap shots 2nd generation

Plastic (polymer) solar cells

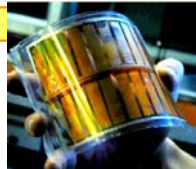

Black CIGS, transparent front electrode

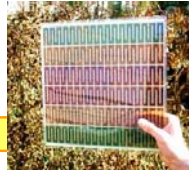

Grätzel cells of various colours, transparent electrodes

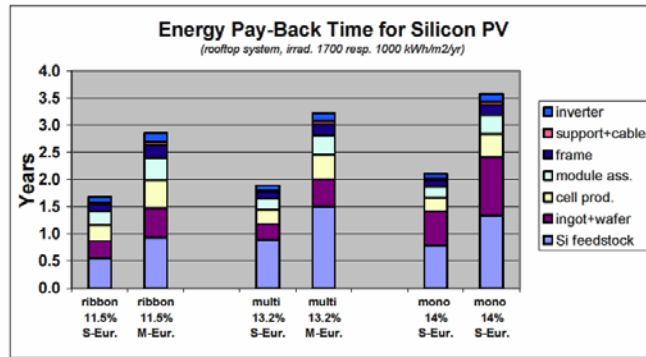
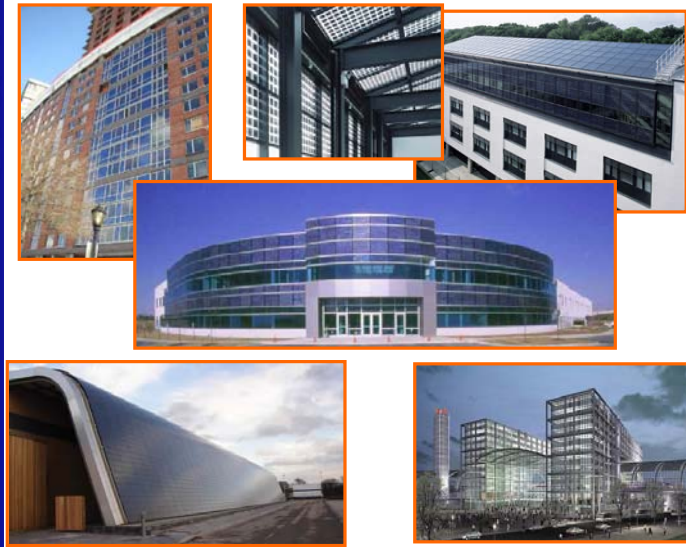

Figure 1: Energy Pay-Back Time (in year) of rooftop PV systems based on crystalline silicon technology at two different locations, South-Europe with 1700 kWh/m²/yr irradiation and Middle-Europe with 1000 kWh/m²/yr. Module efficiencies are shown for each technology; system Performance Ratio 0.75

Energy consumption in the future

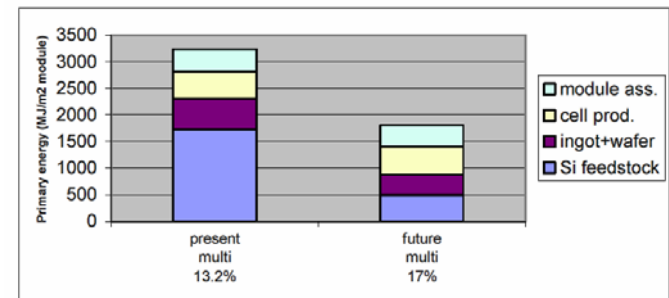

Figure 2: Comparison of primary energy input (MJ per m² module) of present with future multicrystalline silicon module.

Thin film solar cells (2nd generation)

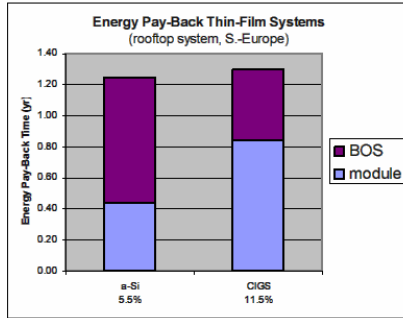

Figure 7: Energy Pay-Back Time for two thin film technologies, as reported by the SENSE project [8]. Rooftops system in S. Europe, Performance Ratio= 0.75. (Preliminary data).

Emission of greenhouse gases

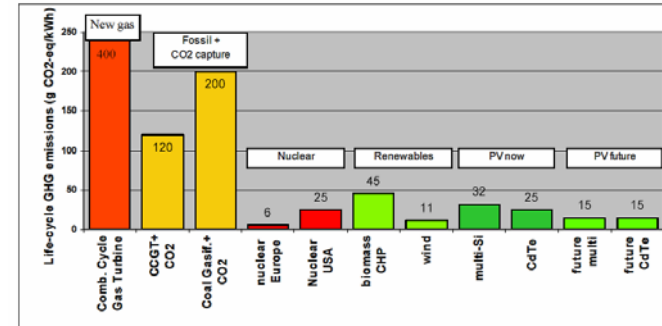

Figure 9: Comparison of GHG emissions of different energy supply options, PV systems installed in S.-Europe (Sources: [12, 13, 14])

Summary part 2

- First generation solar cells are made of crystalline silicon at a relative cost of 3.5\$/W
- Second generation solar cells are made of cheaper materials, normally in the form of thin films. Cost 1\$/W.
- For both 1st and 2nd generation are single junction solar cells (one pn-junction/absorber material) and the efficiency limit is 31% for un-concentrated solar radiation, and 41% for full concentration.
- Third generation solar cells try to overcome the two most important fundamental loss mechanisms (thermalization and transmission), by the use of the following concepts
 - hot-carrier cells (with slow thermalization and special contacts)
 - multiple bandgaps
 - impact ionization for QE>1
- Instead of altering the solar cells one can also alter the solar spectrum before it enters the solar cell.